

Air-Conditioners For Building Application INDOOR UNIT

PLFY-P•VCM-E2

For use with the R410A, R407C & R22 Για χρήση με τα R410A, R407C και R22
Bei Verwendung von R410A, R407C & R22 Para utilização com o R410A, R407C e o R22
A utiliser avec le R410A, R407C et le R22 R410A, R407C ve R22 ile beraber kullanmak için
Bij gebruik van R410A, R407C & R22 Для использования с моделями R410A, R407C и R22
Para utilizar con el R410A, R407C y el R22 使用R410A, R407C和R22制冷剂
Usó del refrigerante R410A, R407C e R22

INSTALLATION MANUAL

For safe and correct use, please read this installation manual thoroughly before installing the air-conditioner unit.

FOR INSTALLER

INSTALLATIONSHANDBUCH

Zum sicheren und ordnungsgemäßen Gebrauch der Klimaanlage das Installationshandbuch gründlich durchlesen.

FÜR INSTALLATEURE

MANUEL D'INSTALLATION

Veillez lire le manuel d'installation en entier avant d'installer ce climatiseur pour éviter tout accident et vous assurer d'une utilisation correcte.

POUR L'INSTALLATEUR

INSTALLATIEHANDLEIDING

Voor een veilig en juist gebruik moet u deze installatiehandleiding grondig doorlezen voordat u de airconditioner installeert.

VOOR DE INSTALLATEUR

MANUAL DE INSTALACIÓN

Para un uso seguro y correcto, lea detalladamente este manual de instalación antes de montar la unidad de aire acondicionado.

PARA EL INSTALADOR

MANUALE DI INSTALLAZIONE

Per un uso sicuro e corretto, leggere attentamente questo manuale di installazione prima di installare il condizionatore d'aria.

PER L'INSTALLATORE

ΕΓΧΕΙΡΙΔΙΟ ΟΔΗΓΙΩΝ ΕΓΚΑΤΑΣΤΑΣΗΣ

Για ασφάλεια και σωστή χρήση, παρακαλείστε διαβάσετε προσεκτικά αυτό το εγχειρίδιο εγκατάστασης πριν αρχίσετε την εγκατάσταση της μονάδας κλιματισμού.

ΓΙΑ ΑΥΤΟΝ ΠΟΥ ΚΑΝΕΙ ΤΗΝ ΕΓΚΑΤΑΣΤΑΣΗ

MANUAL DE INSTALAÇÃO

Para segurança e utilização correctas, leia atentamente este manual de instalação antes de instalar a unidade de ar condicionado.

PARA O INSTALADOR

MONTAJ ELKİTABI

Emniyetli ve doğru biçimde nasıl kullanılacağını öğrenmek için lütfen klima cihazını monte etmeden önce bu elkitabını dikkatle okuyunuz.

MONTÖR İÇİN

РУКОВОДСТВО ПО УСТАНОВКЕ

Для осторожного и правильного использования прибора необходимо тщательно ознакомиться с данным руководством по установке до выполнения установки кондиционера.

ДЛЯ УСТАНОВИТЕЛЯ

安装说明书

在安装空调机之前，请先通读此安装说明书，以便安全正确地使用。

安装人员适用**English****Deutsch****Français****Nederlands****Español****Italiano****Ελληνικά****Português****Türkçe****Русский****中文**

Contents

1. Safety precautions.....	2	4. Electrical work	6
2. Installing the indoor unit	2	5. Installing the grille.....	8
3. Refrigerant pipe and drain pipe	4	6. Test run.....	10

1. Safety precautions

- ▶ Before installing the unit, make sure you read all the "Safety precautions".
- ▶ Please report to your supply authority or obtain their consent before connecting this equipment to the power supply system.

Warning:
Describes precautions that must be observed to prevent danger of injury or death to the user.

Caution:
Describes precautions that must be observed to prevent damage to the unit.

After installation work has been completed, explain the "Safety precautions," use, and maintenance of the unit to the customer according to the information in the Operation Manual and perform the test run to ensure normal operation. Both the Installation Manual and Operation Manual must be given to the user for keeping. These manuals must be passed on to subsequent users.

- Warning:**
- Ask the dealer or an authorized technician to install the air conditioner.
 - Install the unit at a place that can withstand its weight.
 - Use the specified cables for wiring.
 - Use only accessories authorized by Mitsubishi Electric and ask the dealer or an authorized technician to install them.
 - Do not touch the heat exchanger fins.
 - Install the air conditioner according to this Installation Manual.

- Caution:**
- Do not use the existing refrigerant piping, when use R410A or R407C refrigerant.
 - Use ester oil, either oil or alkylbenzene (small amount) as the refrigerator oil to coat flares and flange connections, when use R410A or R407C refrigerant.
 - Do not use the air conditioner where food, pets, plants, precision instruments, or artwork are kept.
 - Do not use the air conditioner in special environments.
 - Ground the unit.

- ⊘ : Indicates an action that must be avoided.
- ⚠ : Indicates that important instructions must be followed.
- ⚡ : Indicates a part which must be grounded.
- ⚠ : Indicates that caution should be taken with rotating parts.
- ⚠ : Indicates that the main switch must be turned off before servicing.
- ⚠ : Beware of electric shock.
- ⚠ : Beware of hot surface.
- ⚠ ELY: At servicing, please shut down the power supply for both the Indoor and Outdoor Unit.

Warning:
Carefully read the labels affixed to the main unit.

- Have all electric work done by a licensed electrician according to local regulations.
- If the air conditioner is installed in a small room, measures must be taken to prevent the refrigerant concentration from exceeding the safety limit even if the refrigerant should leak.
- The cut face punched parts may cause injury by cut, etc. The installers are requested to wear protective equipment such as gloves, etc.

- Install an leak circuit breaker, as required.
- Use power line cables of sufficient current carrying capacity and rating.
- Use only a circuit breaker and fuse of the specified capacity.
- Do not touch the switches with wet fingers.
- Do not touch the refrigerant pipes during and immediately after operation.
- Do not operate the air conditioner with the panels and guards removed.
- Do not turn off the power immediately after stopping operation.

2. Installing the indoor unit

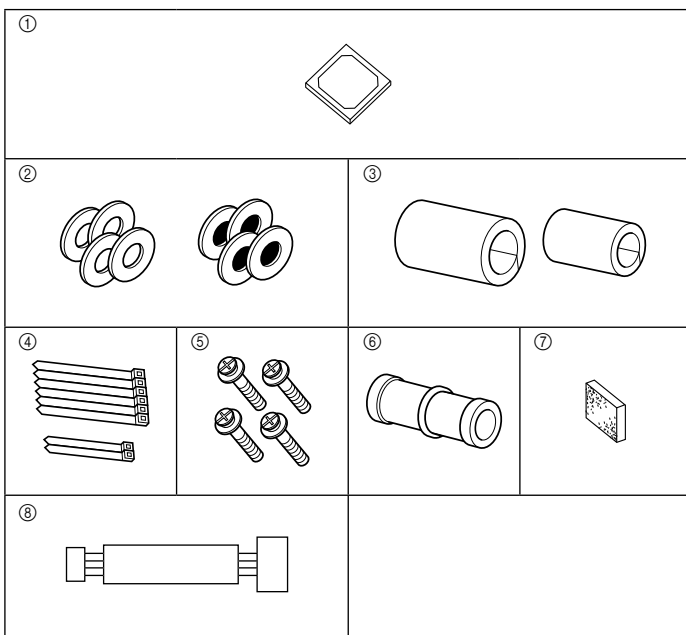

Fig. 2-1

2.1. Check the indoor unit accessories (Fig. 2-1)

The indoor unit should be supplied with the following accessories.

	Accessory name	Q'ty
①	Installation template	1
②	Washers (with insulation)	4
	Washers (without insulation)	4
③	Pipe cover (for refrigerant piping joint)	
	small diameter (liquid)	1
	large diameter (gas)	1
④	Band (large)	6
	Band (small)	2
⑤	Screw with washer (M5 × 25) for mounting grille	4
⑥	Drain socket	1
⑦	Insulation	1
⑧	Wireless junction cable	1

2. Installing the indoor unit

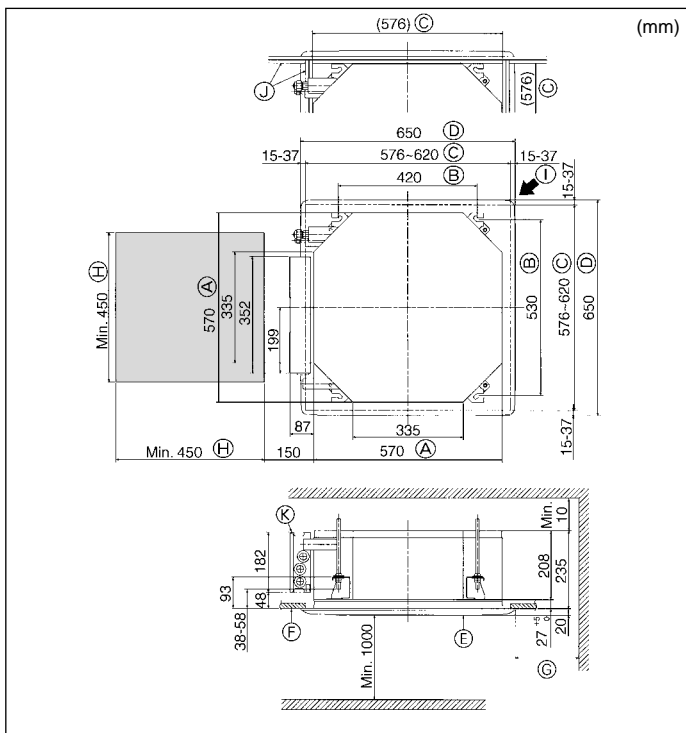

Fig. 2-2

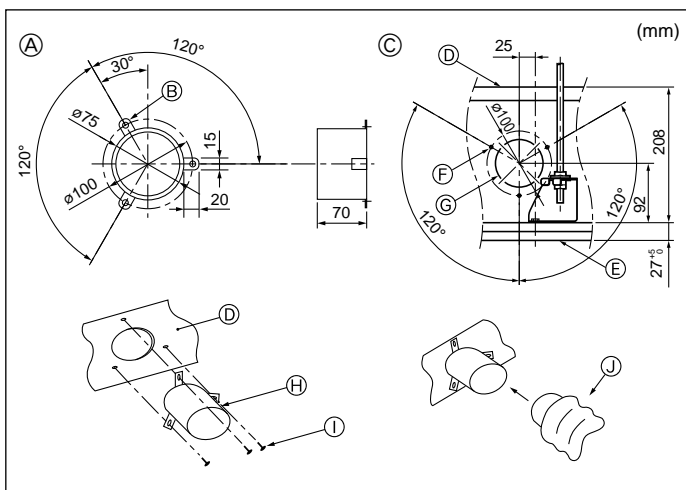

Fig. 2-3

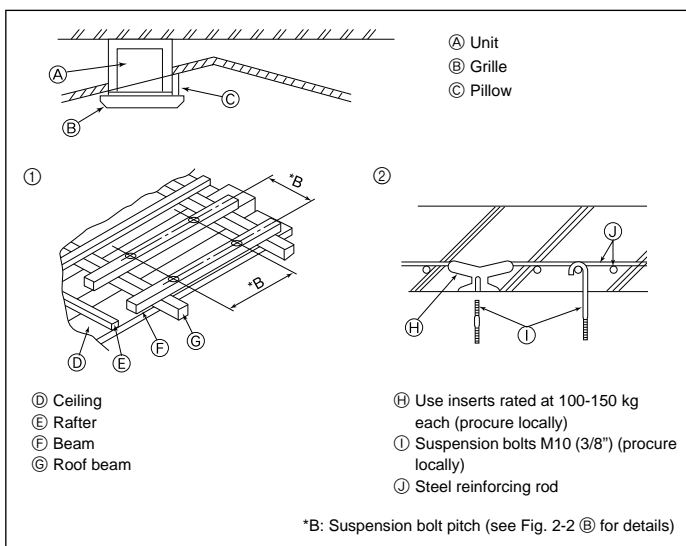

Fig. 2-4

2.2. Ceiling openings and suspension bolt installation locations (Fig. 2-2)

Using the installation template (top of the package) and the gauge (supplied as an accessory with the grille), make an opening in the ceiling so that the main unit can be installed as shown in the diagram. (The method for using the template and the gauge are shown.)

* Before using, check the dimensions of template and gauge, because they change due to fluctuations of temperature and humidity.

* The dimensions of ceiling opening can be regulated within the range shown in following diagram; so center the main unit against the opening of ceiling, ensuring that the respective opposite sides on all sides of the clearance between them becomes identical.

Use M10 (3/8") suspension bolts.

* Suspension bolts are to be procured at the field.

Install securely, ensuring that there is no clearance between the ceiling panel & grille, and between the main unit & grille.

- | | |
|---------------------------|--|
| Ⓐ Outer side of main unit | Ⓔ Min. 500 mm (Entire periphery) |
| Ⓑ Bolt pitch | Ⓜ If setting the maintenance space for Ⓒ, be sure to leave is a minimum of 700 mm. |
| Ⓒ Ceiling opening | Ⓝ Maintenance space |
| Ⓓ Outer side of Grille | Ⓟ Fresh air intake |
| Ⓔ Grille | Ⓠ Angle |
| Ⓛ Ceiling | Ⓡ Electric component box |

* Note that the space between ceiling panel of the unit and ceiling slab and etc. must be 10 to 15 mm to be left.

* Leave the maintenance space at the electric component box end.

2.3. Installation of duct (in case of fresh air intake) (Fig. 2-3)

⚠ Caution:

Linkage of duct fan and air conditioner

In case that a duct fan is used, be sure to make it linked with the air conditioner when outside air is taken.

Do not run the duct fan only. It can cause dew drop.

Making a duct flange (prepared locally)

The shape of duct flange shown left is recommended.

Installation of duct flange

Cut out the cutout hole. Do not knock it out.

Install a duct flange to the cutout hole of the indoor unit with three 4 × 10 tapping screws which should be prepared locally.

Installation of duct (should be prepared locally)

Prepare a duct of which inner diameter fits into the outer diameter of the duct flange.

In case that the environment above the ceiling is high temperature and high humidity, wrap the duct in a heat insulate to avoid causing dew drop on the wall.

- | | |
|---|---|
| Ⓐ Duct flange recommended shape
(Thickness: 0.8 or more) | Ⓠ 3-ø2.8 Burring hole |
| Ⓑ 3-ø5 hole | Ⓡ ø73.4 cutout hole |
| Ⓒ Detail drawing of fresh air intake | Ⓢ Duct flange (Prepared locally) |
| Ⓓ Indoor unit | Ⓣ 4 × 10 Tapping screw (Prepared locally) |
| Ⓔ Ceiling surface | Ⓤ Duct |

2.4. Suspension structure (Give site of suspension strong structure) (Fig. 2-4)

The ceiling work differs according to the construction of the building. Building constructors and interior decorators should be consulted for details.

(1) Extent of ceiling removal: The ceiling must be kept completely horizontal and the ceiling foundation (framework: wooden slats and slat holders) must be reinforced in order to protect the ceiling from vibration.

(2) Cut and remove the ceiling foundation.

(3) Reinforce the ends of the ceiling foundation where it has been cut and add ceiling foundation for securing the ends of the ceiling board.

(4) When installing the unit on a slanting ceiling, interlock a pillow between the ceiling and the grille and set so that the unit is installed horizontally.

① Wooden structures

Use tie beams (single storied houses) or second floor beams (two story houses) as reinforcing members.

Wooden beams for suspending air conditioners must be sturdy and their sides must be at least 6 cm long if the beams are separated by not more than 90 cm and their sides must be at least 9 cm long if the beams are separated by as much as 180 cm. The size of the suspension bolts should be ø10 (3/8"). (The bolts do not come with the unit.)

② Ferro-concrete structures

Secure the suspension bolts using the method shown, or use steel or wooden hangers, etc. to install the suspension bolts.

2. Installing the indoor unit

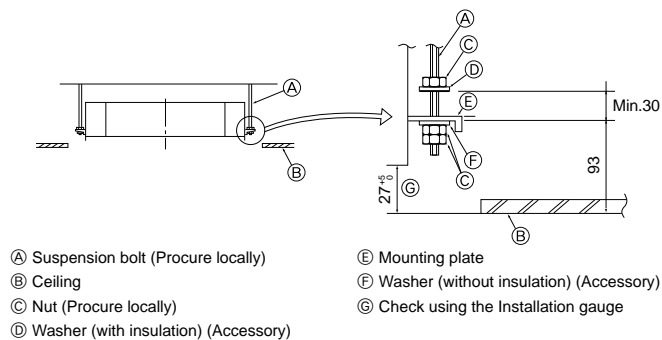

Fig. 2-5

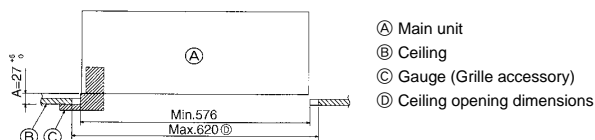

Fig. 2-6

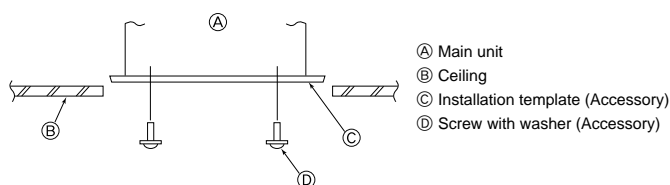

Fig. 2-7

3. Refrigerant pipe and drain pipe

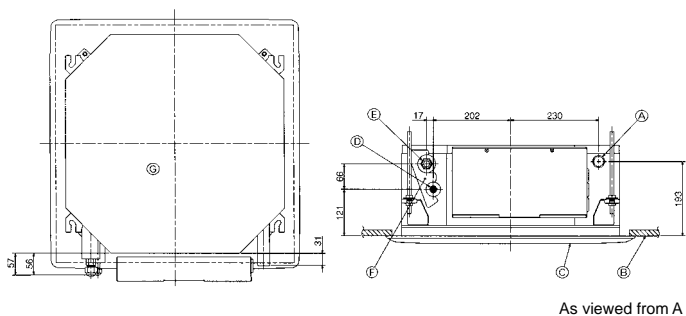

Fig. 3-1

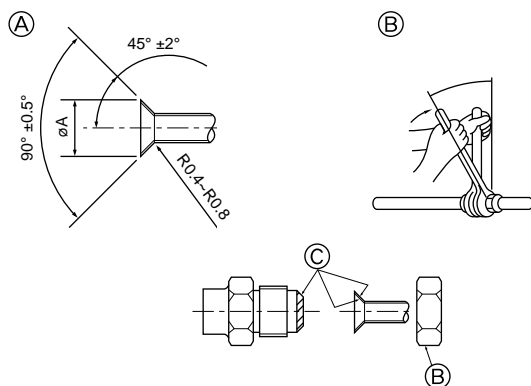

Fig. 3-2

2.5. Unit suspension procedures (Fig. 2-5)

Suspend the main unit as shown in the diagram.

- In advance, set the parts onto the suspension bolts in the order of the washers (with insulation), washers (without insulation) and nuts (double).
 - Fit the washer with cushion so that the insulation faces downward.
 - In case of using upper washers to suspend the main unit, the lower washers (with insulation) and nuts (double) are to be set later.
- Lift the unit to the proper height of the suspension bolts to insert the mounting plate between washers and then fasten it securely.
- When the main unit can not be aligned against the mounting hole on the ceiling, it is adjustable owing to a slot provided on the mounting plate. (Fig. 2-6)
 - Make sure that step A is performed within 27-32 mm. Damage could result by failing to adhere to this range.

2.6. Confirming the position of main unit and tightening the suspension bolts (Fig. 2-7)

- Using the gauge attached to the grille, ensure that the bottom of the main unit is properly aligned with the opening of the ceiling. Be sure to confirm this, otherwise condensation may form and drip due to air leakage etc.
 - Confirm that the main unit is horizontally levelled, using a level or a vinyl tube filled with water.
 - After checking the position of the main unit, tighten the nuts of the suspension bolts securely to fasten the main unit.
 - The installation template can be used as a protective sheet to prevent dust from entering the main unit when the grilles are left unattached for a while or when the ceiling materials are to be lined after installation of the unit is finished.
- * As for the details of fitting, refer to the instructions given on the Installation template.

3.1. Refrigerant and drainage piping locations of indoor unit (Fig. 3-1)

- A Drain pipe
- B Ceiling
- C Grille
- D Refrigerant pipe (liquid)
- E Refrigerant pipe (gas)
- F Water supply inlet
- G Main unit

3.2. Connecting pipes (Fig. 3-2)

- When commercially available copper pipes are used, wrap liquid and gas pipes with commercially available insulation materials (heat-resistant to 100°C or more, thickness of 12 mm or more).
- The indoor parts of the drain pipe should be wrapped with polyethylene foam insulation materials (specific gravity of 0.03, thickness of 9 mm or more).
- Apply thin layer of refrigerant oil to pipe and joint seating surface before tightening flare nut.
- Use two wrenches to tighten piping connections.
- Use refrigerant piping insulation provided to insulate indoor unit connections. Insulate carefully.

A Flare cutting dimensions

Copper pipe O.D. (mm)	Flare dimensions ϕA dimensions (mm)
$\phi 6.35$	8.7 - 9.1
$\phi 9.52$	12.8 - 13.2
$\phi 12.7$	16.2 - 16.6
$\phi 15.88$	19.3 - 19.7
$\phi 19.05$	22.9 - 23.3

3. Refrigerant pipe and drain pipe

Ⓑ Refrigerant pipe sizes & Flare nut tightening torque

	R407C or R22				R410A				Flare nut O.D.	
	Liquid pipe		Gas pipe		Liquid pipe		Gas pipe		Liquid pipe (mm)	Gas pipe (mm)
	Pipe size (mm)	Tightening torque (N·m)	Pipe size (mm)	Tightening torque (N·m)	Pipe size (mm)	Tightening torque (N·m)	Pipe size (mm)	Tightening torque (N·m)		
P20/25/32/40	ODø6.35 (1/4")	14 - 18	ODø12.7 (1/2")	49 - 61	ODø6.35 (1/4")	14 - 18	ODø12.7 (1/2")	49 - 61	17	26
P50	ODø9.52 (3/8")	14 - 18*	ODø15.88 (5/8")	49 - 61*	ODø6.35 (1/4")	14 - 18	ODø12.7 (1/2")	49 - 61	17	26
P63/80	ODø9.52 (3/8")	34 - 42	ODø15.88 (5/8")	68 - 82	ODø9.52 (3/8")	34 - 42	ODø15.88 (5/8")	68 - 82	22	29
P100/125	ODø9.52 (3/8")	34 - 42	ODø19.05 (3/4")	68 - 82*	ODø9.52 (3/8")	34 - 42	ODø15.88 (5/8")	68 - 82	22	29

* Connect the joint with the following pipes: Liquid and gas pipes of P50, gas pipes of P100/P125.

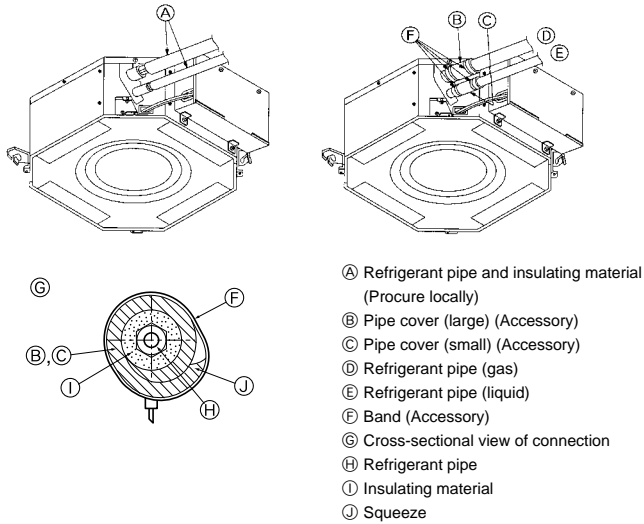

Fig. 3-3

Ⓒ Apply refrigerating machine oil over the entire flare seat surface.

3.3. Indoor unit (Fig. 3-3)

Heat insulation for refrigerant pipes:

- ① Wrap the enclosed large-sized pipe cover around the gas pipe, making sure that the end of the pipe cover touches the side of the unit.
 - ② Wrap the enclosed small-sized pipe cover around the liquid pipe, making sure that the end of the pipe cover touches the side of the unit.
 - ③ Secure both ends of each pipe cover with the enclosed bands. (Attach the bands 20 mm from the ends of the pipe cover.)
- After connecting the refrigerant piping to the indoor unit, be sure to test the pipe connections for gas leakage with nitrogen gas. (Check that there is no refrigerant leakage from the refrigerant piping to the indoor unit.)

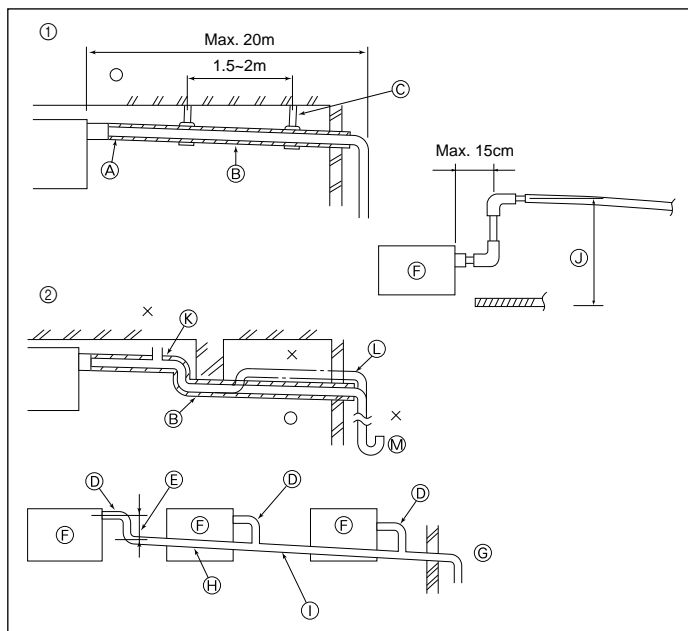

Fig. 3-4

3.4. Drainage piping work (Fig. 3-4)

- Use VP25 (O.D. ø32 (1-1/4") PVC TUBE) for drain piping and provide 1/100 or more downward slope.
- Be sure to connect the piping joints using a polyvinyl type adhesive.
- Observe the figure for piping work.
- Use the included drain hose to change the extraction direction.

- ① Correct piping
 - ② Wrong piping
 - A Insulation (9 mm or more)
 - B Downward slope (1/100 or more)
 - C Support metal
 - K Air bleeder
 - L Raised
 - M Odor trap
- Grouped piping
- Ⓑ O.D. ø32 PVC TUBE
 - Ⓔ Make it as large as possible
 - Ⓕ Indoor unit
 - Ⓖ Make the piping size large for grouped piping.
 - Ⓗ Downward slope (1/100 or more)
 - ① O.D. ø38 PVC TUBE for grouped piping. (9 mm or more insulation)
 - Ⓙ Up to 500 mm

1. Connect the drain socket (supplied with the unit) to the drain port. (Fig. 3-5) (Affix the tube using PVC adhesive then secure it with a band.)
2. Install a locally purchased drain pipe (PVC pipe, O.D. ø32). (Affix the pipe using PVC adhesive then secure it with a band.)
3. Insulate the tube and pipe. (PVC pipe, O.D. ø32 and socket)
4. Check that drain flows smoothly.
5. Insulate the drain port with insulating material, then secure the material with a band. (Both insulating material and band are supplied with the unit.)

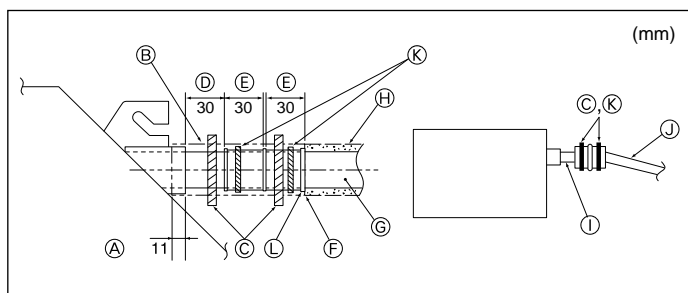

Fig. 3-5

- A Unit
- B Insulating material
- C Band (large)
- D Drain port (transparent)
- E Insertion margin
- F Matching
- G Drain pipe (O.D. ø32 PVC TUBE)
- H Insulating material (purchased locally)
- I Transparent PVC pipe
- J O.D. ø32 PVC TUBE (Slope 1/100 or more)
- K Band (small)
- L Drain socket

4. Electrical work

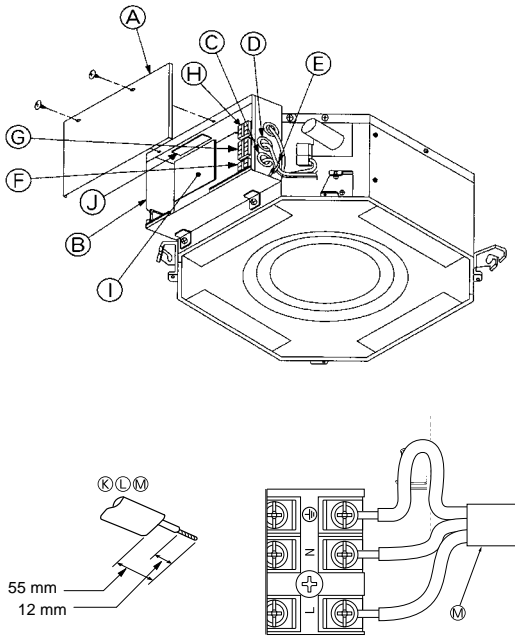

Fig. 4-1

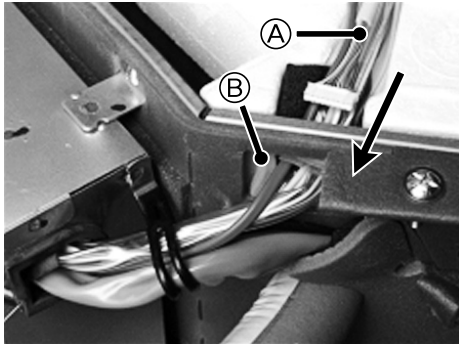

Fig. 4-2

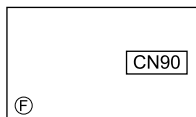
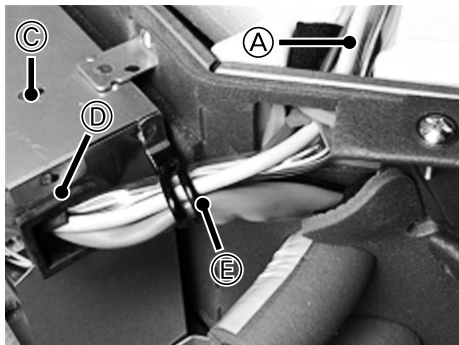

Fig. 4-3

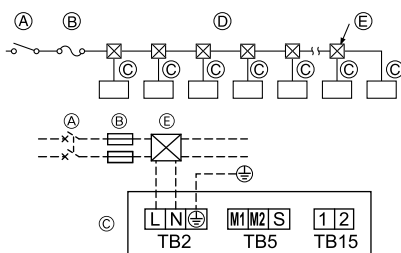

Fig. 4-4

4.1. Indoor unit (Fig. 4-1)

1. Remove 2 screws to detach the electric component cover.
 2. Route each cable through the wiring intake into the electric component box. (Procure power supply cable and control cable locally.)
 3. Securely connect the power supply cable and control cable to the terminal blocks.
 4. Secure the cables with clamps outside the electric component box.
 5. Attach the electric component cover as it was.
- Do not allow slackening of the terminal screws.
 - Always install earth.
- (Earth cable dia: Thicker than 1.6 mm)
- Fix power supply cable and control cable to electric component box by using buffer boxing for tensile force. (PG connection or the like.)

Ⓐ Electric component cover	Ⓞ Transmission terminals (M1, M2, S)
Ⓑ Electric component box	Ⓢ MA Remote controller terminal (1, 2)
Ⓒ Entry for power supply cable	Ⓣ Indoor controller
Ⓓ Entry for remote control cable and transmission cable	Ⓤ Power board
Ⓔ Cable clamp	Ⓥ Remote control cable
Ⓕ Power supply terminals (L, N, ⊕)	Ⓦ Transmission cable
	Ⓧ Power supply cable

- When using the panel with wireless signal receiver "SLP-2ALW", install wireless junction cable for connecting with the cable from the panel through the following steps before installing the main unit.

- (1) Take out the wireless junction cable that is supplied with the accessories.
- (2) Route the indoor controller board connector (white) of the wireless junction cable through the main unit BUSH in the direction indicated by the arrow. (Fig. 4-2)

- (3) Route the wireless junction cable through the electric component box BUSH, and then connect the cable to CN90 of the indoor controller board. (Fig. 4-3)
- (4) Secure the cables and wires with the clamp.

Ⓐ Wireless junction cable (Accessory)
Ⓑ Main unit BUSH
Ⓒ Electric component box
Ⓓ Electric component box BUSH
Ⓔ Clamp
Ⓕ Indoor controller board

4.2. Power supply wiring

- Power supply cable of appliance shall not be lighter than design 245 IEC 53 or 227 IEC 53.
- Install an earth line longer than other cables.
- A switch with at least 3 mm, 1/8 inch contact separation in each pole shall be provided by the air conditioner installation.

Power cable size : more than 1.5 mm² (3-core)

[Fig. 4-4]

Ⓐ Switch 16 A
Ⓑ Overcurrent protection 16 A
Ⓒ Indoor unit
Ⓓ Total operating current be less than 16 A
Ⓔ Pull box

- ▶ Selecting non-fuse breaker (NF) or earth leakage breaker (NV). For breaker, means shall be provided to ensure disconnection of all active phase conductors of the supply.

4. Electrical work

4.3. Types of control cables

1. Wiring transmission cables

Types of transmission cable	Shielding wire CVVS or CPEVS
Cable diameter	More than 1.25 mm ²
Length	Less than 200 m

2. M-NET Remote control cables

Types of remote control cable	Shielding wire MVVS
Cable diameter	More than 0.5 to 1.25 mm ²
Length	Add any portion in excess of 10 m to within the longest allowable transmission cable length 200 m.

3. MA Remote control cables

Types of remote control cable	2-core cable (unshielded)
Cable diameter	0.3 to 1.25 mm ²
Length	Less than 200 m

4.4. Connecting remote controller, indoor and outdoor transmission cables (Fig. 4-5)

- Connect indoor unit TB5 and outdoor unit TB3. (Non-polarized 2-wire) The "S" on indoor unit TB5 is a shielding wire connection. For specifications about the connecting cables, refer to the outdoor unit installation manual.
- Install a remote controller following the manual supplied with the remote controller.
- Connect the remote controller's transmission cable within 10 m using a 0.75 mm² core cable. If the distance is more than 10 m, use a 1.25 mm² junction cable.

① MA Remote controller

- Connect the "1" and "2" on indoor unit TB15 to a MA remote controller. (Non-polarized 2-wire)
- DC 9 to 13 V between 1 and 2 (MA remote controller)

② M-NET Remote controller

- Connect the "M1" and "M2" on indoor unit TB5 to a M-NET remote controller. (Nonpolarized 2-wire)
- DC 24 to 30 V between M1 and M2 (M-NET remote controller)

③ Wireless remote controller (When installing wireless signal receiver)

- Connect the wire of wireless signal receiver (9-pole cable) to CN90 of indoor controller board.
- When more than two units are run under group control using wireless remote controller, connect TB15 each with the same number.
- To change Pair No. setting, refer to installation manual attached to wireless remote controller. (In the default setting of indoor unit and wireless remote controller, Pair No. is 0.)

- Ⓐ Terminal block for indoor transmission cable
- Ⓑ Terminal block for outdoor transmission cable (M1(A), M2(B), ⊕(S))
- Ⓒ Remote controller
- Ⓓ Wireless signal receiver
- Ⓔ Wireless remote controller

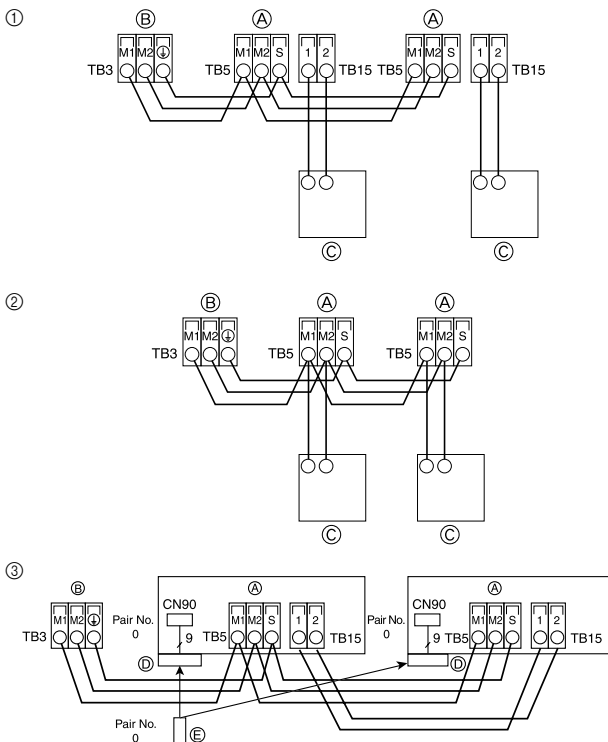

Fig. 4-5

4.5. Setting addresses (Fig. 4-6)

(Be sure to operate with the main power turned OFF.)

- There are two types of rotary switch setting available: setting addresses 1 to 9 and over 10, and setting branch numbers.

① How to set addresses

Example: If Address is "3", remain SW12 (for over 10) at "0", and match SW11 (for 1 to 9) with "3".

② How to set branch numbers SW14 (Series R2 only)

Match the indoor unit's refrigerant pipe with the BC controller's end connection number.

Remain other than series R2 at "0".

- The rotary switches are all set to "0" when shipped from the factory. These switches can be used to set unit addresses and branch numbers at will.

- The determination of indoor unit addresses varies with the system at site. Set them referring to the Data Book.

4.6. Sensing room temperature with the built-in sensor in a remote controller

If you want to sense room temperature with the built-in sensor in a remote controller, set SW1-1 on the control board to "ON". The setting of SW1-7 and SW1-8 as necessary also makes it possible to adjust the air flow at a time when the heating thermometer is OFF.

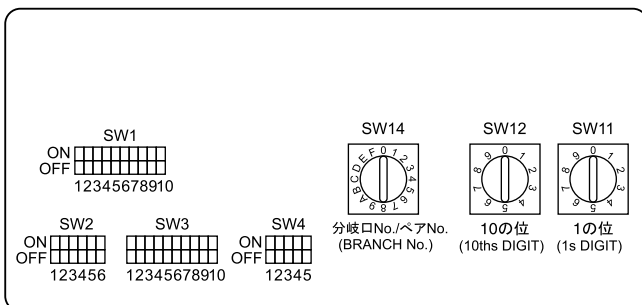

Fig. 4-6

5. Installing the grille

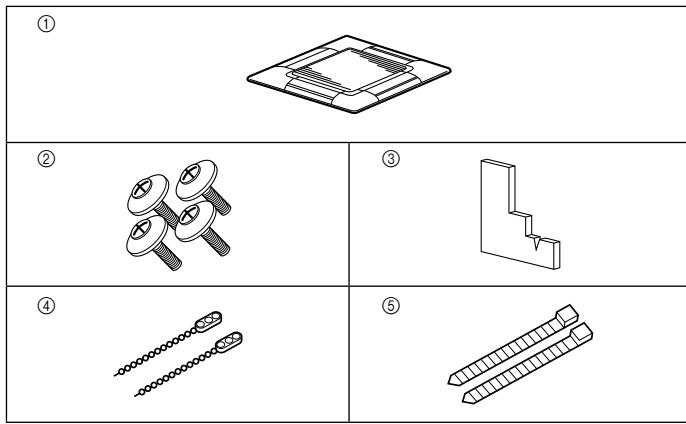

Fig. 5-1

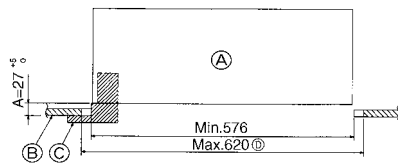

Fig. 5-2

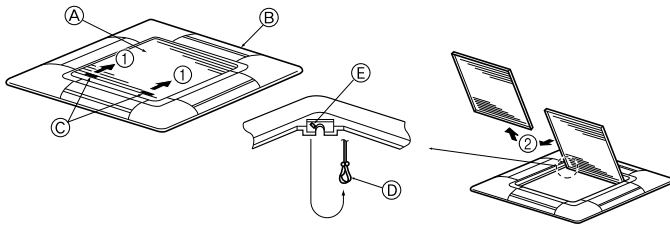

Fig. 5-3

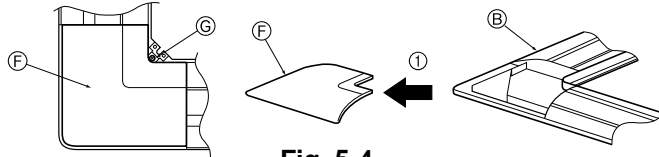

Fig. 5-4

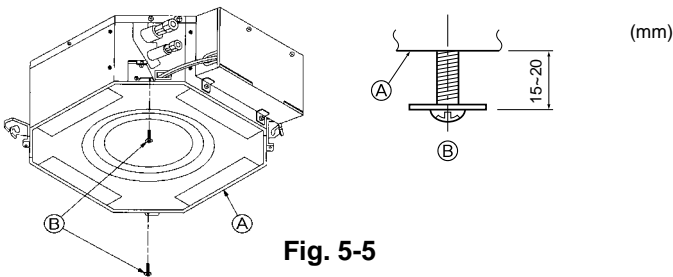

Fig. 5-5

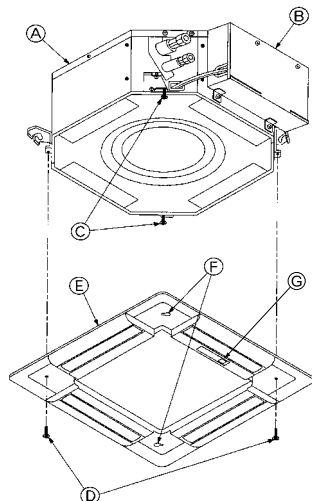

Fig. 5-6

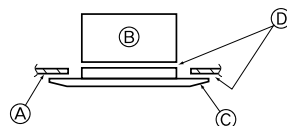

Fig. 5-7

5.1. Check the grille accessories (Fig. 5-1)

- The grille should be supplied with the following accessories.

	Accessory name	Q'ty	Remark
①	Grille	1	650 × 650 (mm)
②	Screw with washer	4	M5 × 0.8 × 25 (mm)
③	Gauge	1	
④	Fastener	2	
⑤	Band	2	

5.2. Preparing to attach the grille (Fig. 5-2)

- With the gauge supplied with this kit, adjust and check the positioning of the unit relative to the ceiling. If the unit is not properly positioned in the ceiling, there may be air leaks, condensation may form, or the up/down vanes may not operate correctly.
- Make sure that the opening in the ceiling is within the following tolerances: 576 × 576 - 620 × 620
- Make sure that step A is performed within 27-32 mm. Damage could result by failing to adhere to this range.
 - Ⓐ Main unit
 - Ⓑ Ceiling
 - Ⓒ Gauge (Accessory)
 - Ⓓ Ceiling opening dimensions

5.2.1. Removing the intake grille (Fig. 5-3)

- Slide the levers in the direction indicated by the arrow ① to open the intake grille.
- Unlatch the hook that secures the grille.
 - * Do not unlatch the hook for the intake grille.
- With the intake grille in the "open" position, remove the hinge of the intake grille from the grille as indicated by the arrow ②.

5.2.2. Removing the corner panel (Fig. 5-4)

- Remove the screw from the corner of the corner panel. Slide the corner panel as indicated by the arrow ① to remove the corner panel.
 - Ⓐ Intake grille
 - Ⓑ Grille
 - Ⓒ Intake grille levers
 - Ⓓ Grille hook
 - Ⓔ Hole for the grille's hook
 - Ⓕ Corner panel
 - Ⓖ Screw

5.3. Installing the grille

- Please pay attention because there is a restriction in the attachment position of the grille.

5.3.1. Preparations (Fig. 5-5)

- Install the two enclosed screws with washer in the main unit (at the corner refrigerant pipe area and at the opposite corner) as shown in the diagram.
 - Ⓐ Main unit
 - Ⓑ Detailed diagram of installed screw with washer (accessory).

5.3.2. Temporary installation of the grille (Fig. 5-6)

- Align the electric component box of the main unit and the receiver of the grille, and then temporarily secure the grille using the bell shaped holes.
 - * Make sure that the lead wiring of the grille does not get pinched between the grille and the main unit.
- Ⓐ Main unit
- Ⓑ Electric component box
- Ⓒ Screw with washer (for temporary use)
- Ⓓ Screw with washer (Accessory)
- Ⓔ Grille
- Ⓕ Bell shaped hole
- Ⓖ Receiver (for SLP-2ALW)

5.3.3. Securing the grille (Fig. 5-7)

- Secure the grille to the main unit by tightening the previously installed two screws (with captive washer) as well as the two remaining screws (with captive washer).
 - * Make sure that there are no gaps between the main unit and the grille or the grille and the ceiling.
- Ⓐ Ceiling
- Ⓑ Main unit
- Ⓒ Grille
- Ⓓ Make sure that there are no gaps.

5. Installing the grille

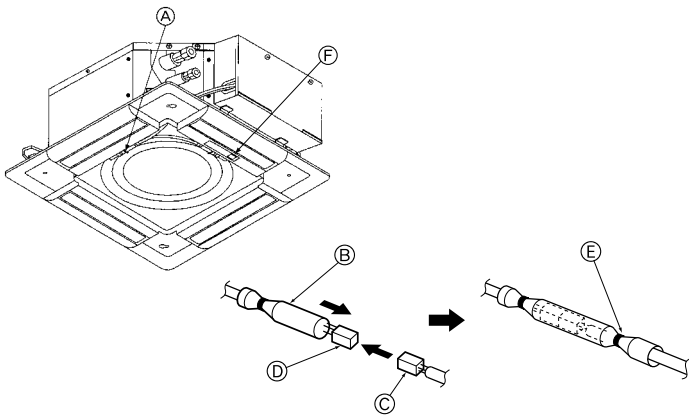

Fig. 5-8

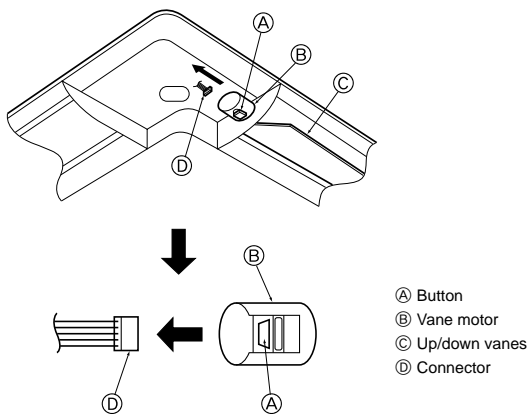

Fig. 5-9

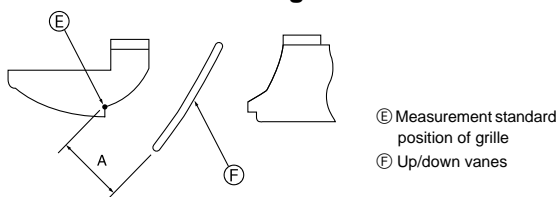
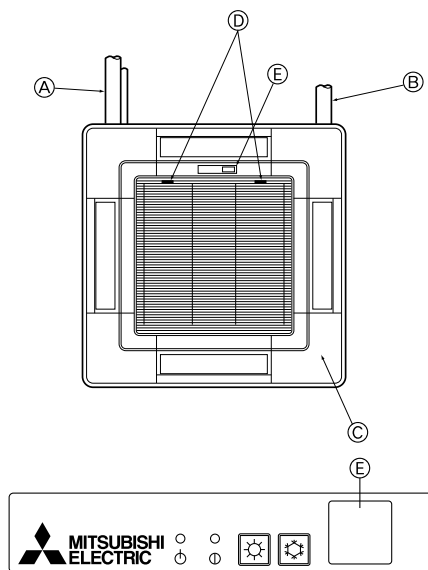

Fig. 5-10



SLP-2ALW
Fig. 5-11

5.3.4. Wire connection (Fig. 5-8)

- Be sure to connect the unit to the connector (white:10-pole/red:9-pole). Next, attach the white glass tube that comes with the main unit so that the tube covers the connector. Close the opening of the glass tube with the band.
- Make sure that there is no slack in the each lead wire at the fastener on the grille.
 - Ⓐ Fastener (Accessory)
 - Ⓑ White glass tube
 - Ⓒ Connector of the main unit
 - Ⓓ Connector of the grille
 - Ⓔ Band (Accessory)
 - Ⓕ Receiver (for SLP-2ALW)

5.4. Locking the up/down airflow direction (Fig. 5-9)

The vanes of the unit can be set and locked in up or down orientations depending upon the environment of use.

- Set according to the preference of the customer.
 - The operation of the fixed up/down vanes and all automatic controls cannot be performed using the remote controller. In addition, the actual position of the vanes may differ from the position indicated on the remote controller.
- ① Turn off the main power switch.
 - Injuries and or an electrical shock may occur while the fan of the unit is rotating.
- ② Disconnect the connector for the vane motor of the vent that you want to lock. (While pressing the button, remove the connector in the direction indicated by the arrow as shown in the diagram.) After removing the connector, insulate it with tape.
- ③ To adjust the desired airflow direction, slowly move the up/down vanes within the specified range. (Fig.5-10)

Specified range

Up/down airflow direction	Horizontal 30°	Downward 45°	Downward 55°	Downward 70°
A (mm)	21	25	28	30

- The vanes can be set between 21 and 30 mm.

⚠ Caution:

Do not set the up/down vanes passed the specified range. Condensation could form on and drop from the ceiling, or the unit could malfunction.

5.5. Installing the intake grille (Fig. 5-11)

- Perform the procedure that is described in "5.2. Preparing to attach the grille" in reverse order to install the intake grille and the corner panel.
 - Ⓐ Refrigerant piping of the main unit
 - Ⓑ Drain piping of the main unit
 - Ⓒ Corner panel
 - * Installation in any position is possible.
 - Ⓓ Position of the levers on the intake grille when sent from the factory.
 - * Although the clips can be installed in any of four positions.
 - Ⓔ Receiver (for SLP-2ALW)

5.6. Check

- Make sure that there is no gap between the unit and the grille, or between the grille and the surface of the ceiling. If there is any gap between the unit and the grille, or between the grille and the surface of the ceiling, it may cause dew to collect.
- Make sure that the wires have been securely connected.

6. Test run

6.1. Before test run

- ▶ After completing installation and the wiring and piping of the indoor and outdoor units, check for refrigerant leakage, looseness in the power supply or control wiring, wrong polarity, and no disconnection of one phase in the supply.
- ▶ Use a 500-volt megohmmeter to check that the resistance between the power supply terminals and ground is at least 1.0 MΩ.

- ▶ Do not carry out this test on the control wiring (low voltage circuit) terminals.
- ⚠ **Warning:**
Do not use the air conditioner if the insulation resistance is less than 1.0 MΩ.

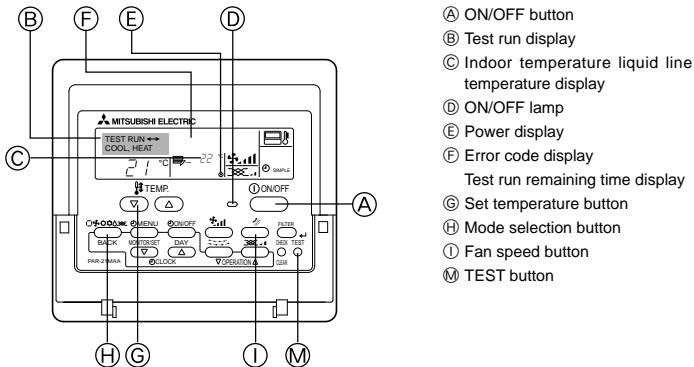

Fig. 6-1

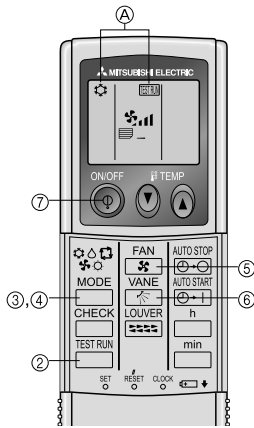

Fig. 6-2

6.2. Test run







The following 3 methods are available.

6.2.1. Using wired remote controller (Fig. 6-1)

- ① Turn on the power at least 12 hours before the test run.
- ② Press the [TEST] button twice. → "TEST RUN" liquid crystal display
- ③ Press the [Mode selection] button. → Make sure that wind is blown out.
- ④ Press the [Mode selection] button and switch to the cooling (or heating) mode. → Make sure that cold (or warm) wind is blown out.
- ⑤ Press the [Fan speed] button. → Make sure that the wind speed is switched.
- ⑥ Check operation of the outdoor unit fan.
- ⑦ Release test run by pressing the [ON/OFF] button. → Stop
- ⑧ Register a telephone number.

The telephone number of the repair shop, sales office, etc., to contact if an error occurs can be registered in the remote controller. The telephone number will be displayed when an error occurs. For registration procedures, refer to the operation manual for the indoor unit.

6.2.2. Using wireless remote controller (Fig. 6-2)

- ① Turn on the power to the unit at least 12 hours before the test run.
- ② Press the  button twice continuously.
(Start this operation from the status of remote controller display turned off.)
A  and current operation mode are displayed.
- ③ Press the  button to activate COOL mode, then check whether cool air is blown out from the unit.
- ④ Press the  button to activate HEAT mode, then check whether warm air is blown out from the unit.
- ⑤ Press the  button and check whether fan speed changes.
- ⑥ Press the  button and check whether the auto vane operates properly.
- ⑦ Press the ON/OFF button to stop the test run.

Note:

- Point the remote controller towards the indoor unit receiver while following steps ② to ⑦.
- It is not possible to run the in FAN, DRY or AUTO mode.

6.3. Check of drainage (Fig. 6-3)

- During the trial run, ensure the water is being properly drained out and that no water is leaking from joints.
 - Always check this during installation even if the unit is not required to provide cooling/drying at that time.
 - Similarly, check the drainage before finishing ceiling installation in a new premises.
- (1) Remove the cover of the water supply inlet and add about 1000 cc of water using a water supply pump etc. During this process, be careful not to spray water into the drain pump mechanism.
 - (2) Confirm that water is being drained out through the drainage outlet, after switching over from remote control mode to trial run mode.
 - (3) After checking the drainage, ensure that the cover is replaced and the power supply is isolated.
 - (4) After confirming the drainage system is functioning, replace the drain plug.

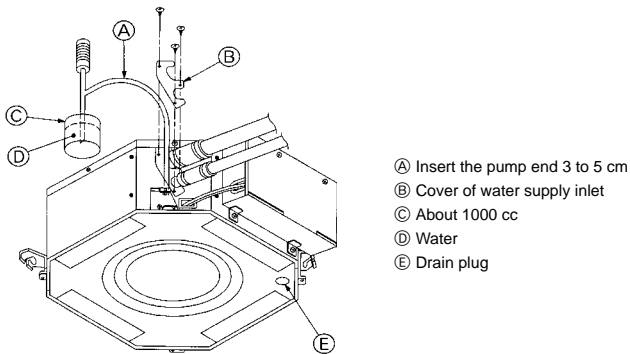

Fig. 6-3

This product is designed and intended for use in the residential,
commercial and light-industrial environment.

The product at hand is based on the following EU regulations:

- Low Voltage Directive 2006/95
- Electromagnetic Compatibility Directive 2004/108 EEC

Please be sure to put the contact address/telephone number on
this manual before handing it to the customer.

 **MITSUBISHI ELECTRIC CORPORATION**
HEAD OFFICE: TOKYO BLDG., 2-7-3, MARUNOUCHI, CHIYODA-KU, TOKYO 100-8310, JAPAN
Authorized representative in EU: MITSUBISHI EUROPE, B.V. HARMAN HOUSE,
1 GEORGE STREET, UXBRIDGE,
MIDDLE SEX UB8 1QQ.U.K.